



the 3-cup espro press

The espro press is a precision coffee brewer. It preserves all of the freshly brewed flavours and aromas by micro-filtering twice with a unique metal filter. This micro-filter keeps grounds out of your cup, and lets aromatic oils in.

assembly

- before using, clean all parts in warm soapy water
- assembling the bottom filter and top filter when wet, will ease assembly (coffee **DOES NOT** go inside the filter)

a few words about coffee

- aim for medium roasts - they have a lot of flavour
- buy fresh and use within 2 weeks of roasting for max flavour
- keep in a cool, dry, dark place to keep it fresh
- grind just before brewing to maintain the delicate aromas
- use a burr grinder (not a blade grinder) for an even extraction

safety

- place the press on a flat stable surface before pressing the filter down, so that it does not slip
- hold onto the container handle with one hand, while using the other hand to press the filter knob
- if it requires too much force to press the filter, see the hints section
- the vacuum sealed double walls of the espro press keep your coffee very hot - please be careful when pouring and drinking
- the lid may get hot

how to use

step 1: BREW

- preheat container to maintain heat
- mix fresh, coarse ground coffee (-22 g) and hot water (~300 ml, ~95 °C)

advanced techniques:

- pour the water in slowly, to gently mix the water and coffee (don't mix yet)
- leave empty space at top for the filter
- exactly half way through brewing, gently swirl the press and break up the grounds at the stop for a more even extraction
- put on the lid to keep the heat in

step 2: MICROFILTER

- insert filter
- press gently to the bottom

advanced techniques:

- don't mix just before pressing as this will disturb the grounds and get some fines into your coffee

step 3: ENJOY

- preheat your cup
- pour, and enjoy

advanced techniques:

- use a spoon to slurp some coffee and air and you will taste some of the subtler flavors in the coffee
- experiment with mass, time, temperature to get the most out of your beans

product specifications

- standard 3-cup size (about 8 oz of coffee)
- constant temperature with stainless double wall vacuum
- durable and easy to clean
- US and global patents pending

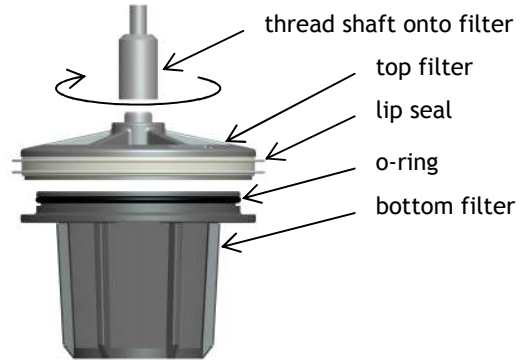



cleaning options

- separate the top and bottom filter, and clean with soft bristle brush (not included)
- dishwasher, top rack
- assemble the top and bottom filter when wet, to ease assembly



hints - here are some hints to improve your pressing technique - try one at a time

coffee is too weak:

1. use more coffee - aim for 6 to 8 g per 100 ml of water
2. brew longer - aim for 2 to 4 minutes
3. grind finer
4. mix more - mix or swirl half way through brewing (don't mix just before pressing, as this can get grinds in your coffee)

coffee is too strong:

1. use less coffee - aim for 6 to 8 g per 100 ml of water
2. reduce brew time - aim for 2 to 3 minutes
3. grind coarser

coffee is bitter:

1. try a medium roast - over-roasted coffee is carbonized
2. reduce water temperature - water should not be boiling
3. reduce brew time to avoid overextraction
4. use arabica beans rather than robusta beans
5. use more coffee - aim for 6 to 8 g per 100 ml of water
6. grind coarser to avoid overextraction

coffee is sour:

1. increase water temperature - just below boiling

can't push filter down

1. grind coarser - you may need to increase brewing time
2. mix more - this will also improve extraction - mix near the beginning, or half way through extraction (don't mix just before pressing, as this can get grinds in your coffee)
3. use a burr grinder - coffee fines produced by blade grinders can clog filters, and make coffee taste bad
4. when the force gets too high, pull the filter up very slightly once (1 to 2 mm, 1/32" to 1/16"), then continue pushing to the bottom - this may increase fines slightly

warranty

- your espro press is covered by a one year limited warranty from the date of purchase
- for warranty claims, please contact espro directly at info@espro.ca
- our mailing address:

Espro Inc.
169-3495 Cambie Street
Vancouver, BC
V5Z 4R3